



HMG 系列镁合金注射成型机  
HMG Thixomolding Magnesium Machine

**HMG200-HMG7000**



**宁波保税区海天智胜金属成型设备有限公司**  
Ningbo Free Trade Zone Haitian Zhisheng Die Casting Equipment Co., Ltd.

地址: 浙江省宁波市北仑区大碶街道灵山路8-1号  
ADD: No.8-1 Lingshan Road, Daqi, Beilun, Ningbo, Zhejiang  
邮编 Zipcode: 315806  
电话 Tel: +86-574-86185710  
传真 Fax: +86-574-86185710  
E-Mail: haitiandc@mail.haitian.com



HT 20260318-CV



**铸造未来**  
CASTING THE FUTURE

# HMG

极佳性能、安全和高效的  
镁合金注射成型解决方案

Thixomolding solutions with excellent  
performance, safety and efficiency



海天智胜金属拥有海天集团五十余年装备制造经验，在注射成型领域有着深厚技术底蕴，以及领先的压铸机技术，在联合开发与自主创新的双引擎驱动下，推出了全新的 HMG200-7000 镁合金注射成型机。

Benefited from more than 50 years of machinery manufacturing experience of Haitian Group, Haitian Die Casting possesses profound expertise in terms of thixomolding and die casting machinery. Driven by joint development and in-house innovation, the new HMG200-7000 thixomolding machines have been officially launched.

技术源自 2006 年  
The technology is originated from 2006

## HMG Overview HMG 概览

得益于强大的技术力量，我们设计了全新的镁合金注射成型机，在性能、效率、稳定、安全等方面树立更高标准。HMG系列拥有高刚性、灵活的合模结构；重新整合液压部件，专为高精度、高性能注射成型而研制；采用伺服节能动力系统等技术，可以帮您轻松应对镁合金注射成型需求。

Thanks to strong technical capabilities, we have designed a series of thixomolding machines, setting higher standards in performance, efficiency, stability, and safety. The HMG series features a high-rigidity and flexible clamping structure, integrating hydraulic components specifically developed for high-precision, high-performance thixomolding. Advanced technologies, say, a servo energy-saving power system, can effortlessly help you meet thixomolding needs for sure.

### 强劲 Powerful

基于压铸机设计的高刚性合模结构  
海天独有的机铰运动软件优化分析，  
开合模可任意位置停止，更精准，更高效

High-rigidity clamping structure based  
on die casting machine design  
Haitian's unique hinge motion optimization  
analysis allows molds to stop at any position  
during opening and closing

- ◎ Comprehensive Benefit Improvement
- ◎ Form more complex magnesium alloy products
- ◎ Application results with better density and higher mechanical properties
- ◎ With clamping forces up to 70,000kN
- ◎ With screw diameters up to 200mm
- ◎ Theoretical injection capacity of HMG7000U exceeds 38kg

## Extend the possibilities for magnesium alloy forming 为镁合金成型带来更多可能

- ◎ 综合效益提升
- ◎ 成型更为复杂的镁合金产品
- ◎ 产品将拥有更好的致密度，更高的力学性能
- ◎ 最大锁模力达 70000kN
- ◎ 螺杆最大直径达 200mm
- ◎ HMG7000U 理论注射量超 38kg

### 创新 Innovative

系统压力最高可达 21Mpa  
专为注射成型定制研发的机械、电控、液压系统，可确保  
设备具有高稳定性

System pressure can reach up to 21 MPa  
The mechanical, electrical, and hydraulic systems are  
custom-developed for thixomolding to ensure high  
stability of the equipment.

安全 低碳  
Safe and low-carbon



### 智能 Intelligent

智能 KEBA 控制系统，功能强大  
配置注射、储料曲线快速查看功能  
可与智能工厂管理软件进行数据交互，易拓展

The intelligent and powerful KEBA control system, for quick  
view of injection and storage curves, and it can be configured to  
interact with the intelligent factory management software

### 节能 Energy-efficient

高性能伺服系统，节能可靠  
多重液压油过滤

Energy-saving and reliable high-performance servo system  
Multiple hydraulic oil filtration

## Injection Systems of Excellence 性能卓越的注射系统

- ◎ 双伺服控制注射系统：可配置入口 + 出口双伺服比例阀控制，实现速度精准控制，控制周期 0.25ms，可配置多段注射速度，工艺调节范围更广，具备末端刹车功能，精度更好、重复精度更高。
  - ◎ 注射速度 0.05 -5m/s 无极调速，加速性能卓越。
  - ◎ 计量射退和计量旋转均采用伺服电机控制，控制精度更高，且计量扭矩与转速实时监控。
  - ◎ 注射单元油缸采用锻打钢件，更适配最高 21Mpa 的系统压力。
  - ◎ 储能器和氮气瓶加大，能量充足，压降小，停机自动泄压，注射更强劲更稳定。
  - ◎ 注射电热回路采用固态继电器，料筒双传感器测温，更稳定，更安全。
- 
- ◎ Dual servo-controlled injection system: It can be configured with both inlet and outlet dual servo proportional valve control to achieve precise speed control. The control cycle is 0.25ms, and it can be configured with multiple injection speeds, offering a wider range of process adjustments. It features end brake function, with better accuracy and higher repeatability.
  - ◎ Injection speed ranges from 0.05 to 5m/s with stepless speed regulation and excellent acceleration performance.
  - ◎ Both metering retreat and metering rotation are controlled by servo motors, providing higher control accuracy and real-time monitoring of metering torque and speed.
  - ◎ The injection unit's oil cylinder is made of forged steel, making it better suited for the maximum system pressure of 21 MPa.
  - ◎ The enlarged accumulator and nitrogen bottle ensure ample energy, minimal pressure drop, and automatic pressure release during shutdown, making the injection stronger and more stable.
  - ◎ The injection heating circuit uses solid-state relays, and the barrel features dual sensor temperature measurement for greater stability and safety.



## Thixomolding Schematic

### 镁合金注射成型原理图

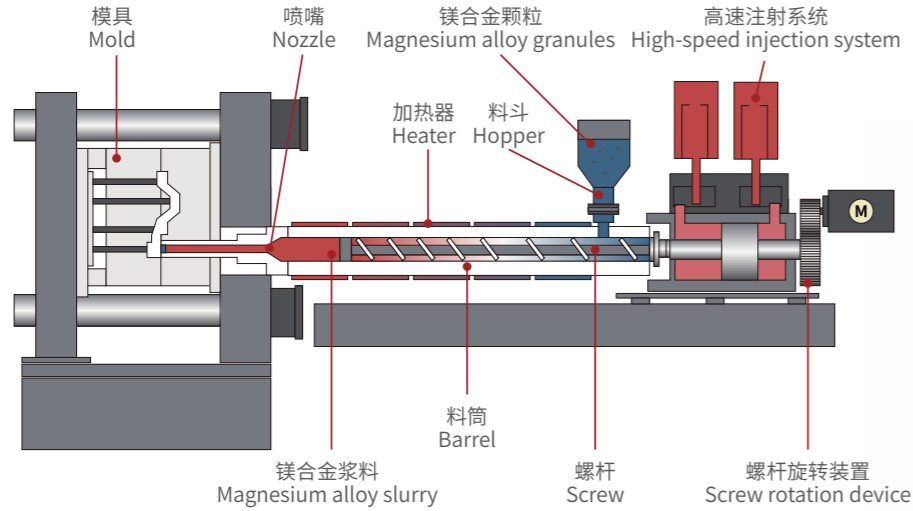

## Five Edges of Thixomolding

### 镁合金注射成型五大优势



**安全：**镁合金注射成型过程封闭，无需熔炼炉  
**Safety:** Thixomolding process is enclosed, eliminating the need for a melting furnace.



**低碳：**无需使用 SF6 保护气体  
**Low-carbon:** No need for SF6 protective gas.



**品质：**产品致密性好，气孔、渣孔有效减少，力学性能提升  
**Quality:** The product has good density, effectively reducing pores and slag holes, and improving mechanical properties.



**节能：**材料利用率高，仅融化所需材料量，减少能耗  
**Energy Saving:** High material utilization rate, melting only the required amount of material, reducing energy consumption.



**低温：**汤液温度低 (<620°C)，模具寿命长，产品尺寸精度高  
**Low Temperature:** The molten metal temperature is low (<620°C), resulting in longer mold life and high product dimensional accuracy.

## Magnesium Alloy: The Green Engineering Material of the 21st Century

### 21 世纪的绿色工程材料：镁合金

**1 密度低，比强度、比刚度高：**  
 镁合金密度是铝的 2/3，钢的 1/5，1kg 镁合金坚固程度等于 1.8kg 铝合金，等于 2.1kg 的钢。

**Low density, high specific strength and stiffness:**

The density of magnesium alloy is 2/3 that of aluminum and 1/5 that of steel. 1 kg of magnesium alloy has the same strength as 1.8 kg of aluminum alloy and 2.1 kg of steel.

**2 阻尼减振性能好：**  
 镁合金受冲击载荷时，吸收能力约为铝合金的 1.5 倍，是工程塑料的 20 倍。

**Excellent damping and vibration reduction performance:**

When subjected to impact loads, magnesium alloy absorbs about 1.5 times more energy than aluminum alloy and 20 times more than engineering plastics.

**3 散热性能强：**  
 镁合金比热容是铝的 1/3，镁合金散热效率比铝合金高约 60%。

**Strong heat dissipation performance:**

The specific heat capacity of magnesium alloy is 1/3 that of aluminum. The heat dissipation efficiency of magnesium alloy is about 60% higher than that of aluminum alloy.



**4 再生性好，绿色环保：**  
 镁是易于回收的金属，可 100% 回收再利用。

**Good recyclability, environmentally friendly:**

Magnesium is a metal that is easy to recycle and can be 100% recycled and reused.

**5 中国镁储量高：**  
 中国具有丰富的镁矿资源，约占世界镁矿资源的 70%。

**Rich magnesium reserves in China:**

China has abundant magnesium resources, accounting for about 70% of the world's magnesium resources.

# Magnesium Alloy Products 镁合金产品

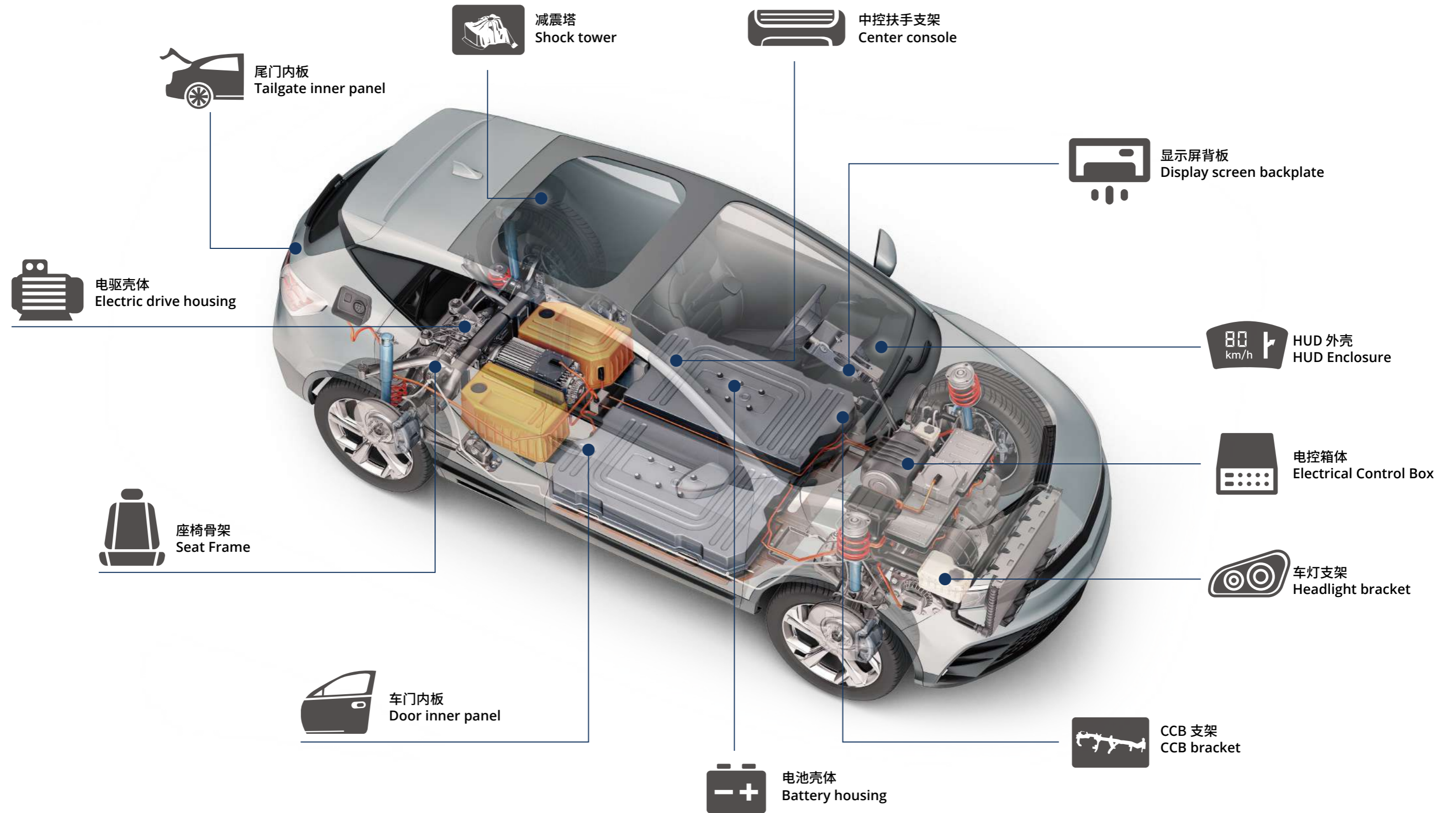

# Top View of Equipment 设备俯视图

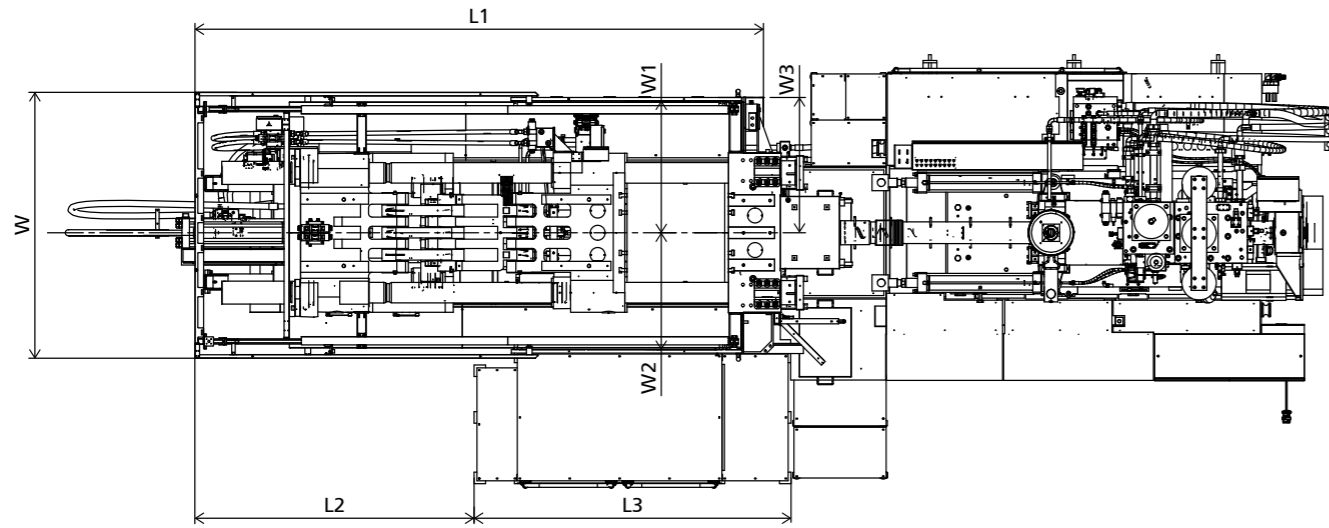

200、350、500、700、850 机型适用  
Applicable to models 200, 350, 500, 700, and 850

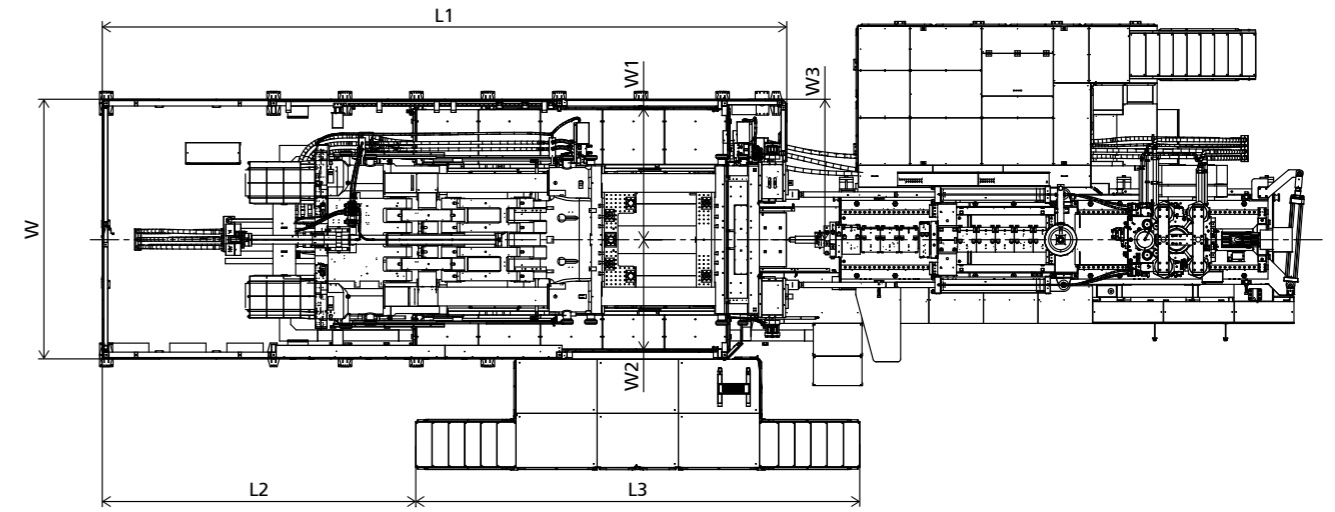

1300、1650、2000、3200、3600、5000 机型适用  
Applicable to models 1300, 1650, 2000, 3200, 3600, 5000

Safety distance between front and rear doors of the machine body  
机身前后门安全距离

机型	HMG200	HMG350	HMG500	HMG700	HMG850	HMG1300	HMG1650	HMG2000	HMG3200	HMG3600	HMG5000
宽度 W Machine width W	1730	1800	2083	2311	2814	3740	3852	4000	4770	4800	5170
安全门内间距 W1 Safety door inner spacing W1	825	880	891	1140	1280	1810	1856	1935	2388	2472	2576
安全门内间距 W2 Safety door inner spacing W2	700	760	814	1010	1280	1510	1685	1755	2044	2070	2197
取件机最大间距 W3 Maximum distance W3 between extractor and machine	905	960	1035	1218	1407	2017	2011	2090	2557	2597	2782
合模部分长度 L1 Clamping unit length L1	2960	3500	4200	4932	5157	8542	9211	9566	11486	12652	13017
钣金至外平台长度 L2 Length from Sheet Metal to Outer Platform L2	-	-	-	2422	3770	3938	4613	3508	4708	5764	6184
操作侧外平台长度 L3 Length of Operator Side Outer Platform L3	-	-	-	2750	1696	5826	5826	7326	8266	8266	8266

单位 unit: mm

## Technical Parameters

## 技术参数

		HMG200	HMG350	HMG500	HMG700	HMG850	HMG1300	HMG1650	HMG2000	HMG3200	HMG3600	HMG5000						
锁模力	Clamping force	kN	2000	3500	5000	7000	8500	13000	16500	20000	32000	36000	50000					
开模行程	Mold opening stroke	mm	400	460	580	670	760	1000	1200	1400	1550	1600	1900					
模厚 (最小 - 最大)	Mold thickness (Min-Max)	mm	250-600	250-700	350-850	350-900	400-950	450-1200	530-1430	640-1640	840-2040	840-2040	940-2240					
模板尺寸 (水平 × 垂直)	Platen size (Horizontal×Vertical)	mm	765×765	910×910	1180×1180	1380×1380	1470×1470	1730×1760	2000×2000	2135×2135	2605×2605	2730×2630	3085×2985					
拉杆内间距 (水平 × 垂直)	Dist. between tie bars (Horizontal×Vertical)	mm	510×510	570×570	770×770	860×860	930×930	1090×1090	1250×1250	1350×1350	1650×1650	1750×1650	1965×1865					
顶出力	Ejection force	kN	125	180	212	212	360	560	560	630	900	900	1000					
顶出行程	Ejection stroke	mm	90	80	120	120	150	210	210	300	300	300	400					
螺杆直径	Screw diameter	mm	45	50	55	66	84	92	100	110	130	130	150	150	180	180	200	
计量行程	Metering stroke	mm	150	150	150	150	300	300	300	300	350	350	350	350	350	450	450	450
理论注射容量	Theoretical injection volume	cm <sup>3</sup>	191	236	285	411	1496	1795	2121	2566	4245	4245	5650	5650	5650	10682	10682	13188
理论注射重量	Theoretical injection weight	g	344	424	513	739	2693	3229	3815	4618	7640	7640	10170	10170	10170	19228	19228	23738
最大射出压力	Maximum injection pressure	MPa	69	56	65	61	63	77	65	67	77	77	64	64	64	70	70	58
理论射出率	Theoretical injection rate	cm <sup>3</sup> /s	7952	9817	11879	17106	27709	33238	39270	47518	66333	66333	88288	88288	88288	127235	127235	157080
喷嘴孔径	Nozzle diameter	mm	10	10	13	13	15	17	17	20	25	25	35	35	35	45	45	60
喷嘴最大伸入量	Maximum nozzle penetration	mm	120	120	150	150	200	200	200	200	275	275	275	275	275	450	450	450
射台位置	Injection seat position	mm	0, -100	0, -100	0, -100	0, -100	0, -175	0, -175	0, -175	0, -200	0, -350	0, -350	0, -350	0, -350	0, -350	0, -400	0, -500	0, -500
最大注射速度	Maximum injection speed	m/s	5	5	5	5	5	5	5	5	5	5	5	5	5	5	5	5
螺杆旋转速度	Screw rotation speed	r/min	0-250	0-250	0-300	0-300	0-250	0-250	0-250	0-250	0-210	0-210	0-210	0-210	0-210	0-150	0-150	0-150
系统工作压力	System working pressure	MPa	19	19	19	20	20	20	19	19	21	21	21	21	21	21	21	21
泵驱动电机功率	Pump drive motor power	kw	14.7	31.4	41.9	56.5	56.5	2×60.5	2×60.5	2×60.5	3×60.5	3×59.6	4×60.5	4×60.5				
加热功率	Heating power	kw	35.2	36.6	67.5	102.7	104	178	178	179	179	179	179	458	458			
熔料伺服电机功率	Melting servo motor power	kw	30.2	40.9	50.7	60.5	78.3	80.5	80.5	107.5	107.5	107.5	168	168				
液压油建议注入量	Hydraulic Oil Filling Volume	L	220	450	655	866	866	1850	1880	1880	1904	1904	2660	2750				
机器吊装重量参考	Machine weight	T	15	18	28	45	53	105	130	130	160	180	286	360				
机器外形尺寸 (长 × 宽 × 高)	Overall dimension (L×W×H)	mm	7000×2200×3400	7200×2200×3200	8900×2500×3700	10900×3600×3670	11300×3970×3950	15600×7200×4900	16600×7400×4900	16600×7400×4900	17000×7450×4900	17500×7530×4900	22400×8200×5600	22700×8500×5700				